

4

3

2

1

B

B

A

A

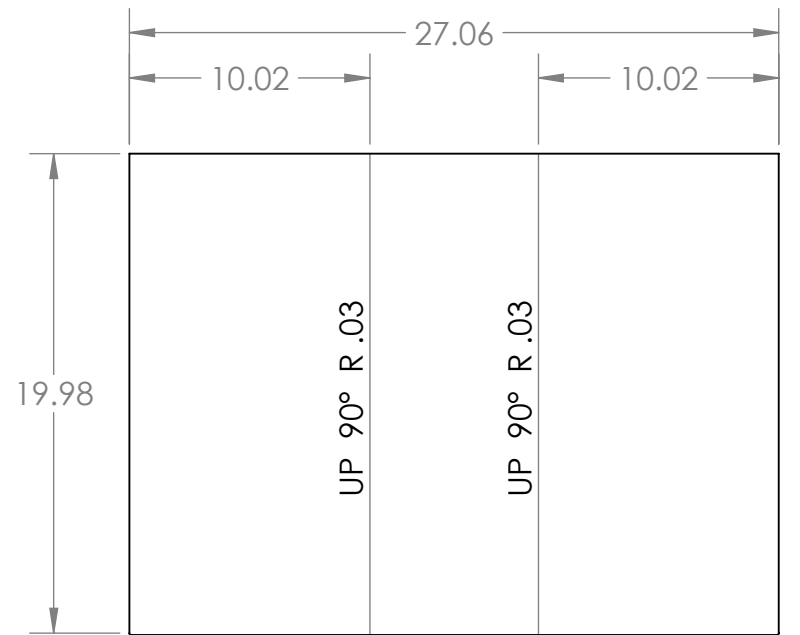
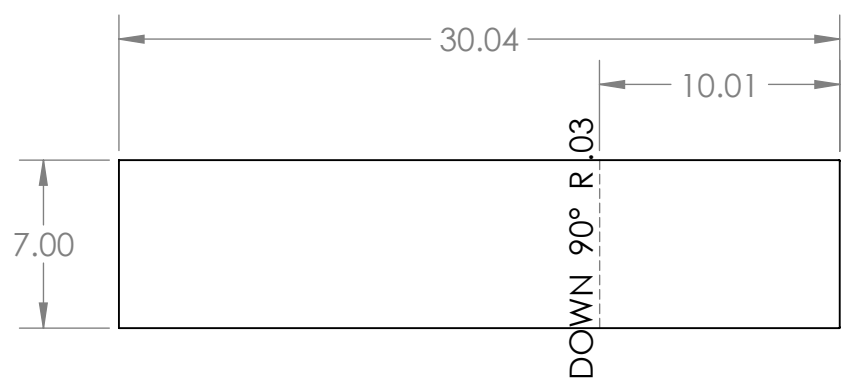
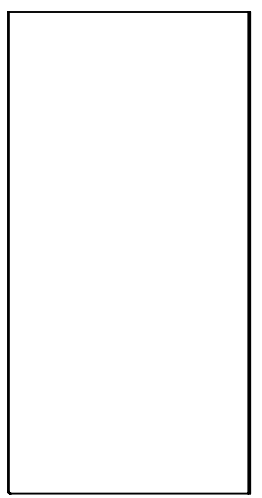
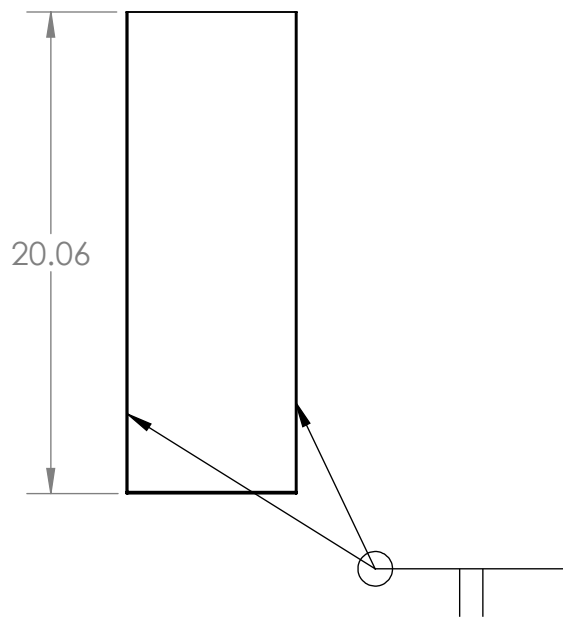
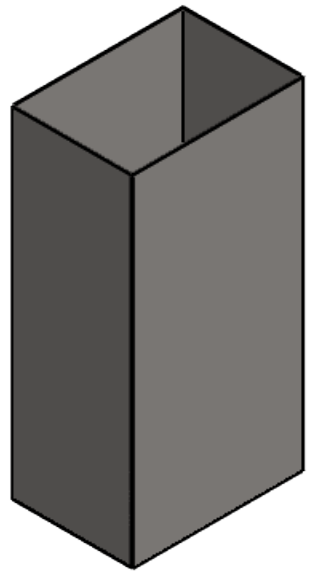
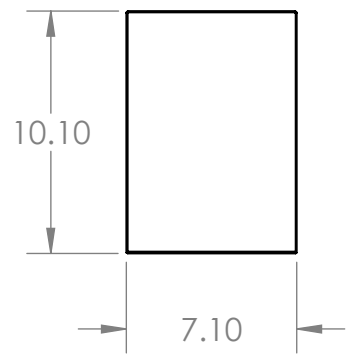

Notes:

1) Weld per D9.1/D9.1M:2018

UNLESS OTHERWISE SPECIFIED:	
DIMENSIONS ARE IN INCHES	
TOLERANCES:	
FRACTIONAL ± 1/16	
ANGULAR: MACH ± .1° BEND ± 1°	
TWO PLACE DECIMAL ± .01	
THREE PLACE DECIMAL ± .005	
INTERPRET GEOMETRIC TOLERANCING PER: ASME Y14.5	
MATERIAL	
18 Gauge 316/316L	
FINISH	
#4 Brush	
DO NOT SCALE DRAWING	

NAME	DATE
Drawn By:	NAM
Board Appr.	
ENG Appr.	NAM
Vendor Appr.	

COMMENTS:

TITLE:		
Central Cemetery		
Mini-Vault		
SIZE	DWG. NO.	REV
<b>B</b>	0002	0
SCALE: 1:8		SHEET 1 OF 1